

Seal-less zero emission LNG pump solutions

How small scale LNG industry can benefit from
the unique properties of submerged motor pumps

David Loughman, Nikkiso Cryo, Inc.

Seal-less zero emission LNG pump solutions

How small scale LNG industry can benefit from the unique properties of submerged motor pumps

By David Loughman
Director of Business Development
Nikkiso Cryo, Inc.

Contact:
David.loughman@nikkisocryo.com
+1-702-643-4900

Nikkiso Cryo, Inc.
4661 Eaker Street
North Las Vegas, NV, 89081

Seal-less zero emission LNG pump solutions

Table of content

1. Introduction _____	3
2. The first applications _____	3
3. Case study 1 – operating near boiling point _____	4
4. Case study 2 – mechanical seal reliability _____	6
5. Case study 3 – sensitivity of seals to pump operation _____	8
6. Key features and benefits of SMP _____	9
6.1. SMP types _____	9
6.2. No shaft seals _____	10
6.3. No thrust bearings and associated bearing lube systems _____	11
6.4. No shaft couplings and critical alignment issue problems _____	11
6.5. No motor failures _____	11
6.6. Special canned motor _____	12
7. Disadvantages of seal type, deepwell or external motor pumps _____	12
8. Zero emissions solution _____	13
9. Safety and hazards _____	14
10. High speed designs and variable speed control _____	15
11. Evaluating life cycle cost _____	15
12. Selecting an LNG pump _____	16
13. Conclusion _____	17
14. References _____	17
15. Bibliography _____	18

Seal-less zero emission LNG pump solutions

1. Introduction

The development of hydraulic fracturing technology and its success in the last five years in unlocking the abundant shale gas resources in North America and worldwide has been described as the single biggest energy development since 1859, when oil was first discovered in the US.

The availability of low cost natural gas, together with new global regulations on emissions, has created innovation and development across the complete LNG supply chain, and given stimulus to the creation of new market sectors. The development of small scale LNG, including the LNG distribution market sectors for onshore, offshore, lake and inland waterways is visible.

Development of these new market sectors has been based on the industrial gas distribution market practices and technologies. A notable difference currently exists between the industrial gas sector and the mid/large scale LNG sector in the respective use of seal vs. seal less type pumps.

As this article will demonstrate, this starting situation is not unexpected, and follows the early trends in other LNG markets prior to switching to seal less only solutions. Submerged motor pumps (SMPs) are used for LNG applications including bunkering/loading, product transfer, vaporizer feed and road/train/barge tankers for cargo off-loading duties. They are also used for pumping both the associated fractionated natural gas liquids (NGLs), such as propane, butane, ethane, etc., and the downstream chemicals and petrochemicals (liquids such as ethylene, propylene and ammonia). SMPs are available in pot mounted, removable and fixed styles, thus providing the maximum flexibility with regard to installation and operation either inside or outside of storage tanks.

2. The first applications

SMPs were introduced to the world LNG market as far back as the early 1960s, when LNG transport by ocean finally became a reality. The SMP was first developed and later employed by J.C. Carter Co. at the Lake Charles LNG plant in the US before being applied to the LNG carrier Beauvais, built in France. After the initial shock of contemplating the presence of electric cabling and motors in a tank full of hydrocarbon liquid, the SMP solution eventually received global approval by the main classification societies of the day, based on the logic of the proposal and

Seal-less zero emission LNG pump solutions

backed by hard facts. The SMPs were finally chosen as the LNG pump standard, replacing the original external motor deep-well cargo pump arrangements (Figure 1) despite intervening efforts by major pump brands to enter the LNG market using seal type pumps.¹

This standardization continues today where all large and medium scale LNG projects, onshore and offshore, are equipped with SMP designs. Identical patterns can be seen in the development and standardization of the submerged generator liquid and liquid/gas expander (SGEs) machines currently being applied.²

The range of equipment supplied has grown with the demands of the market and equipment performance envelope now covers a wide range, as shown in Figure 2. There have been over 10,000 units operating worldwide since the 1960s, with pumps in excess of 2.1 MW in size. In fact, full factory acceptance testing of SMPs at Nikkiso Cryo Inc.'s test facility in Nevada, USA, can be carried out currently using LNG, LPG, or liquid nitrogen up to 3 000 m³/h, total differential head (TDH) 5 000 m and 3.5 MW with continuous run times of over four hours a standard.

3. Case study 1 – operating near boiling point³

Common cryogenic fluids such as argon, nitrogen and oxygen are stored near their atmospheric pressure and pumped near their normal boiling points. These are the most common cryogenic fluids used in the industrial gas industry, which is currently the driver of the small scale LNG business. The fluids are delivered by over-the-road trucks. Each truck uses a single stage centrifugal pump driven by a hydraulic or electric motor to move these liquids from the truck to the storage tanks. One fleet operator with 25 trucks began an aggressive program to reduce failures and improve equipment reliability. An analysis of the operation's seal life and repair costs is shown in Table 1. Not only were the maintenance costs excessive, there were also financial losses when deliveries could not be made.

Seal-less zero emission LNG pump solutions

Conclusion

- The most significant maintenance cost factor is related to the mechanical seal life.
- The most common cause of pump failure is the failure of mechanical seals.
- Total life cycle costs are many multiples times the initial pump cost.
- Seal failure may be reduced and optimized but can never be eliminated.
- Costs do not include lost production and fire and safety risks including increased liability.

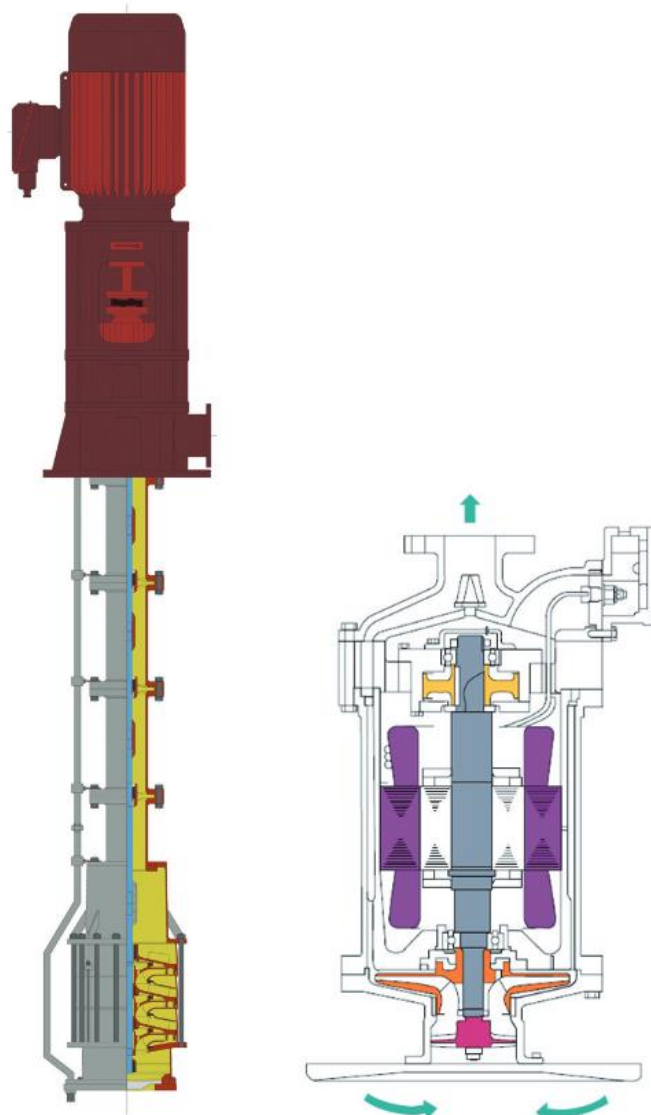

Fig. 1: SMP fixed type vs. external motor pump

Seal-less zero emission LNG pump solutions

Table 1: Analysis of seal life and repair costs for the example cryogenic fluid delivery fleet operation

Cryogenic fluid sealed	Tankers in service	Average seal life in weeks	Failures per year	Costs per year	Achieved savings with minimum seal life of 6 years
Argon	5	6	45	US\$ 67 500	US\$ 405 000
Nitrogen	10	14	35	US\$ 52 500	US\$ 315 000
Oxygen	10	25	20	US\$ 30 000	US\$ 180 000
Costs of maintenance per year				US\$ 150 000	US\$ 0
Total savings over 6 years					US\$ 900 000

4. Case study 2 – mechanical seal reliability

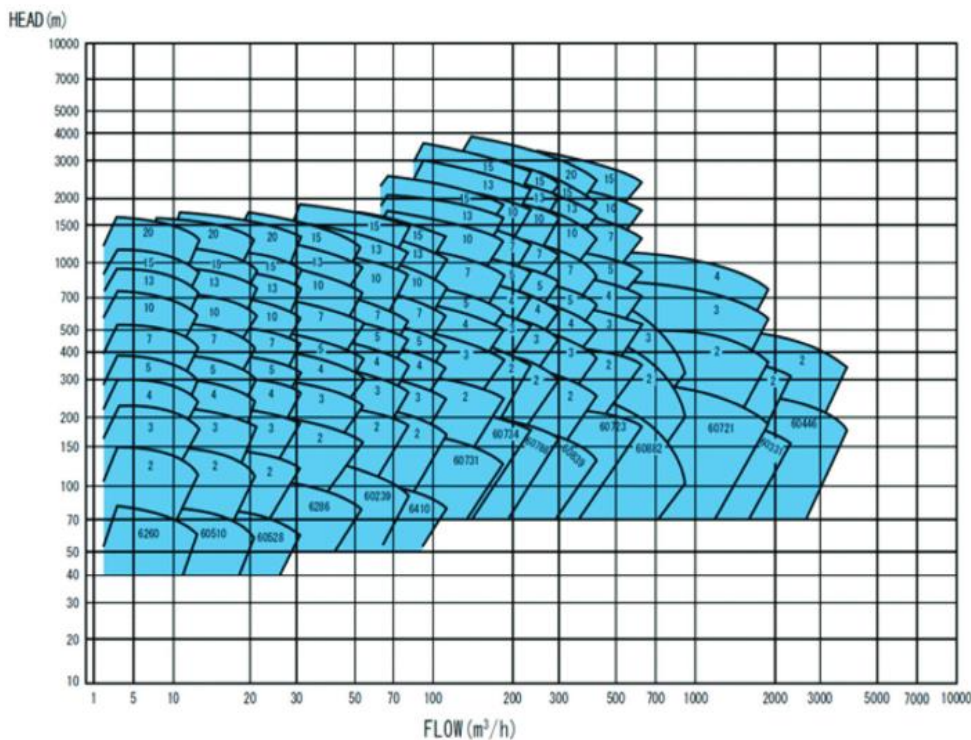

Fig. 2: Typical performance range covered by SMP

Seal-less zero emission LNG pump solutions

It is well known that bearing malfunction often precedes mechanical seal failure in centrifugal process pumps. Statistical information to that effect has recently been published in the technical paper 'Mechanical Seal Reliability – What Realistically can be Achieved', which facilitates assessing the benefits of sound remedial action.⁴

The data of interest were presented at the Mechanical Sealing Technology Seminar, IMechE, London. The presentation reviewed 11 000 mechanical seal failures from 148 different reliability contract and alliance plant sites over a two-year period. The findings are shown in Figure 3. Various studies estimate the world market for mechanical seals at US\$ 3.2 billion/year.

Seal failure case distribution

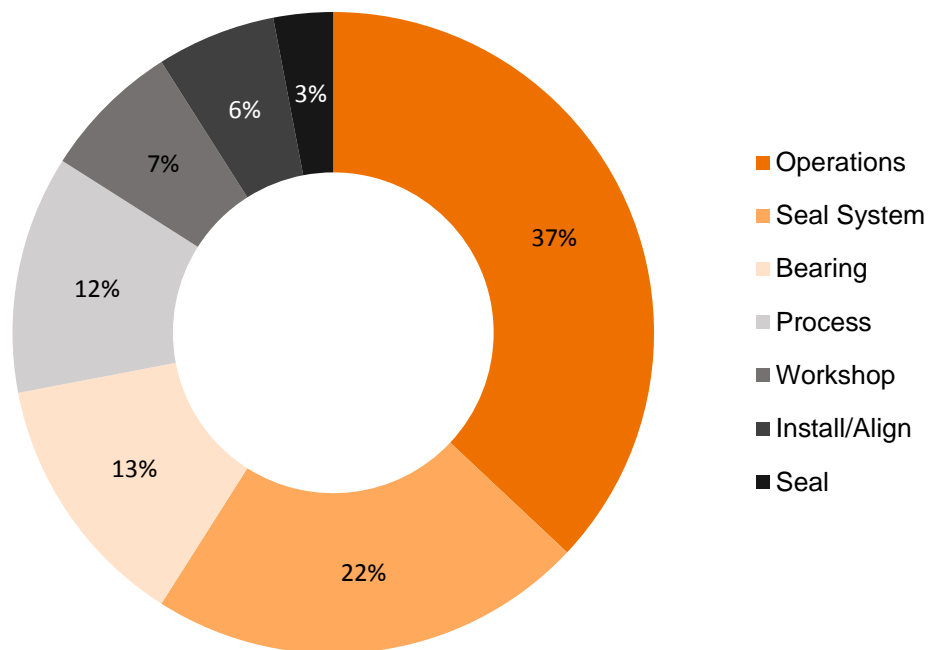

Fig. 3: Seal failure case distribution. Estimated world market for mechanical seals is US\$ 3.2 billion/year.

Seal-less zero emission LNG pump solutions

Conclusion

Seal failure cause costs are distributed as follows:

- Bearings: US\$ 416 million/year.
- Alignment/installation: US\$ 192 million/year.
- Process/operations: US\$ 1560 million/year.
- Seal/seal system: US\$ 832 million/year.

5. Case study 3 – sensitivity of seals to pump operation

In 1996, a major US chemical company conducted an exhaustive study whereby it surveyed the maintenance records of over 6600 chemical process pumps in its various plants and found (Figure 4):

- The most significant maintenance cost factor related to conventional chemical process pumps is mechanical seal life.
- The most common cause of chemical process pump failure is failure of mechanical seals.
- Running chemical process pumps outside of the preferred operating range (80 - 110% of BEP) has a major impact on mechanical seal life and in some cases can reduce mean time between failures by a factor of ten.
- Eliminating mechanical seals from a pump in chemical process duty has the potential to reduce maintenance cost by 65 - 90%.

Seal-less zero emission LNG pump solutions

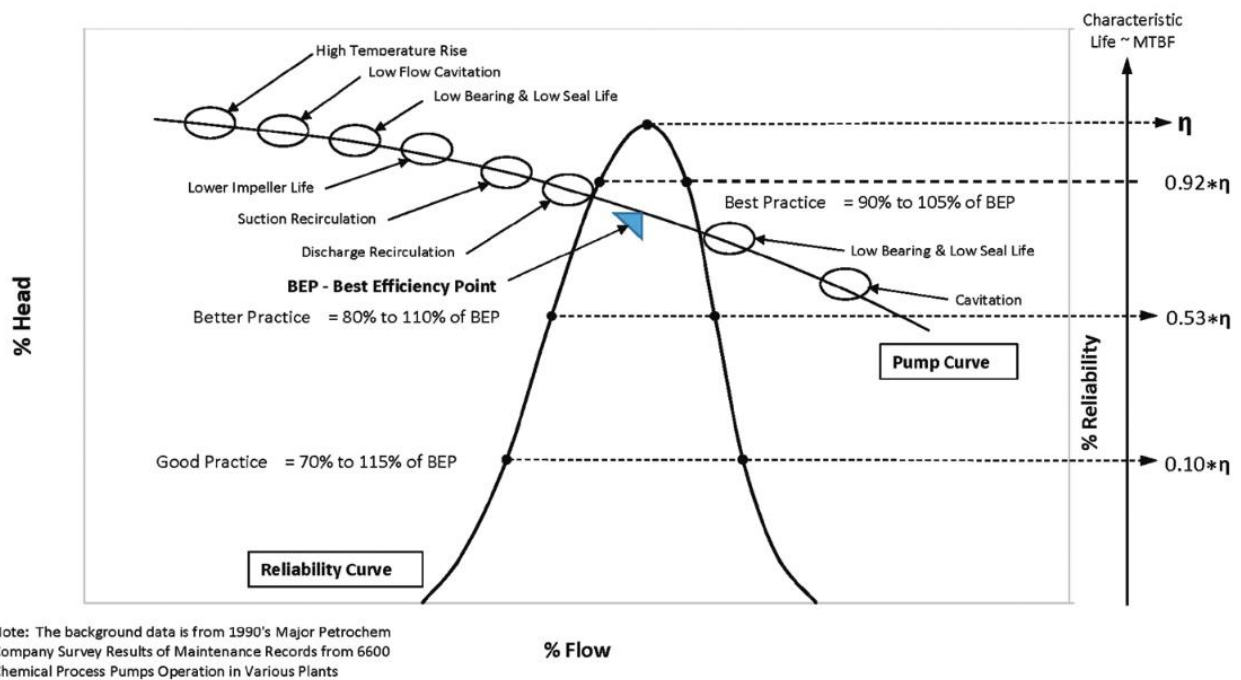

Fig. 4: Sensitivity of seals to pump operation

6. Key features and benefits of SMP⁵

6.1. SMP types

The SMP is a versatile design in that the same basic pump configuration, with all of its features and benefits, can be adapted in a variety of ways to meet various process, transport, transfer and storage applications in various static or dynamic installations. These installation types include suction pot mounted, removable and fixed.

The SMP consists of a single shaft design where the motor and pump hydraulic components (inducer, impellers) are mounted on a common shaft supported by product cooled ball bearings. The total pump assembly is mounted inside a suction pressure vessel and fully submerged in the pumped liquid. Once the entire SMP is cooled down initially and with no sealing or lubrication systems required, the design is on continuous standby and ready for quick start-up at any time. Figure 5 shows a typical SMP layout, in this case mounted inside a suction pot.

Seal-less zero emission LNG pump solutions

The SMP's basic design excludes the key elements associated with the majority of pump failures today in all types of facilities worldwide. The SMP helps eliminate the majority of problems and costs associated with pumping LNG.

6.2. No shaft seals

Whether the seals are contacting or non-contacting types, they will eventually either wear out, fail in operation, or, in some cases, fail while on standby, thereby contaminating the surrounding area, introducing fire and explosion hazards, as well as stopping production and deliveries of LNG. The best solution is to completely eliminate the requirement for seals. Seals by their very nature allow the process liquid to become contaminated by the sealing medium upon failure and contaminate the surrounding areas of the pump with pumped product.

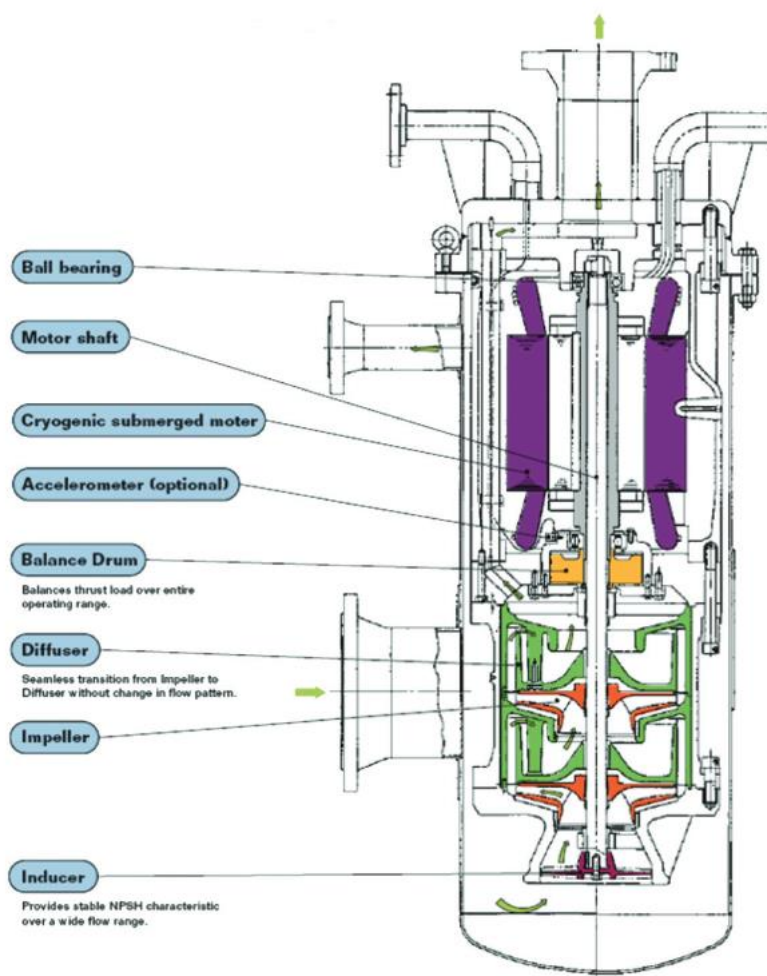

Fig. 5: Suction vessel mounted

Seal-less zero emission LNG pump solutions

6.3. No thrust bearings and associated bearing lube systems

Thrust bearings are designed for limited lifespan operation. This lifespan is further influenced by the need for regular maintenance and monitoring by plant personnel, as well as the cost associated with the consumption of lubricants. In the case of cryogenic installations, lubricants must be prevented from freezing or icing, adding to complication and costs. In the case of the SMP, all thrust is balanced using the balance piston arrangement, whereby the pumped liquid is used to float the rotating assembly, thus allowing the pump bearings to operate unloaded throughout the operating lifespan of the pump. This zero-load operating condition provides theoretically infinite lifespan of the SMP bearings. The thrust balance system is very robust and will operate in even the most extreme circumstances, such as on board Excelerate's FSRU operations during Hurricane Katrina.⁶

SMPs operated continuously within their preferred operating capacity range can achieve in excess of 25 000 hours under field operating conditions.

6.4. No shaft couplings and critical alignment issue problems

The SMP is designed to be fully self-aligning during assembly and repeatable during rebuilds by even the most inexperienced technicians with no need for critical base plate shimming and coupling set up. Cold leakage pathways, from internal cold liquid to external warm ambient moisture laden zone, result in heat-loss problems, which lead to cold spots and icing problems.

Thermal distortion can cause eccentricities in the rotating assembly, resulting in binding during cool down or high vibration during operation.

6.5. No motor failures⁷

The conditions which normally lead to the deterioration and early failure of motors are not present in SMPs. Therefore it is not unusual to find original motors in SMPs that have been operating for up to 40 years in the field, as the motors are fully submerged in the pumped liquid and continuously wet with the process liquid passing through the rotor air gap to ensure homogeneous cooling.

Seal-less zero emission LNG pump solutions

The pumped liquid provides an almost infinite heat-sink, ensuring sufficient cooling, resulting in a very low operating temperature rise (1 – 3 °C). Operating in such cryogenic temperatures also means that the motor sizing is smaller than equivalent external motors due to the superior electrical properties associated with materials at low temperatures. Since the motors are fully submerged in the pumped liquid, they are not exposed to the conditions that lead to deterioration and failure of the insulation system.

Motors suffer short lifespans when operated in areas such as the deck of ships, shore based terminals, refineries, petrochemical and gas plants. These facilities operate in unavoidably severe environments, such as being exposed to marine, saline, brine, wet, condensation, corrosive/erosive environments, ambient temperature fluctuations, chemical attack, UV degradation, and physical damage due to impact from surrounding equipment and structures.

As higher temperatures shorten motor life, it is estimated that for every 10 °C rise in operating temperature, the insulation life is reduced by half. The SMP is much quieter than an external motor design as the fluid acts as a buffer, greatly decreasing the overall noise level transmitted to the outside of the vessel.

6.6. Special canned motor

In the case of pumped liquids that are conductive, erosive or corrosive, there are solutions available where canned motors are incorporated in the SMP replacing the wet motor.

7. Disadvantages of seal type, deepwell or external motor pumps

Some disadvantages of using an external motor pump for LNG or other liquefied gas applications include the following:

- External motor pumps use a complicated seal arrangement, which is difficult to maintain and can fail in operation or on standby if not monitored and maintained on a daily basis.
- In addition to the seal, it is necessary to include a seal oil, gas and/or vapour chamber to control the pressure across the seal. When leakage of the seal into the LNG occurs, these frozen droplets can enter into the pump and damage the pump internals as well as the seal itself and even contaminate the process.

Seal-less zero emission LNG pump solutions

- It is not possible to vent the seal chamber area/barrier pot on initial start-up for proper seal operation and extended life. Any seal pot pressure loss will cause unrecoverable premature seal failure.
- A coupling is used between the motor section and the pump section, which requires careful installation and alignment. If any eccentricity occurs, the seals will fail rapidly.
- Because of the seal chamber area and larger motor, a two-piece shaft system must be used. Maintenance is more difficult and costly, due to the larger footprint and weight of the components.
- The external motor must have an explosion proof housing, and can be quite large in comparison to a submerged motor of the same power. This size will increase loads on the support structure, requiring a more expensive support design.
- The external motor may also use oil filled bearings and require a lube oil system with pumps to supply oil in and out of the bearings, which must be kept warm to avoid freeing and buildup of ice. This adds complexity to the system. In addition, the power required for the lube oil system should be considered when calculating the overall efficiency of the pump/motor.
- Other disadvantages are listed in the bullet points of '5. Case study 3 - sensitivity of seals to pump operation'.

8. Zero emissions solution

With the move toward tighter emissions control standards, especially in and around loading terminals and marine ports, there is a heightened awareness and fresh focus on the benefits of zero emissions pumping solutions. The SMP provides such a solution, which results in a simple and cost-effective means to ensure compliance with current and any future onshore or offshore regulatory emission standards around the world. Such regulations are hard to predict, but failure to comply can result in limitations to the operation of the vessel or the facility. The seal less pumps provide a 'green solution' to LNG pumping.

Seal-less zero emission LNG pump solutions

9. Safety and hazards

SMPs are inherently safe. No explosion proof motor is required since the inside of the suction pot or storage tank is classified as a non-hazardous area in accordance with NFPA 59A, due to the positively pressurized conditions associated with cold boiling liquids inside the tank, which precludes any possible ingress of oxygen. The exclusion of oxygen eliminates a key element of the 'fire triangle', and the compliance with certain specific operational measures results in a safe, non-hazardous operating environment. In addition, the SMP is completely contained within the pressure vessel or storage tank, which is non-accessible to plant personnel except after gas freeing and warming up the equipment, so that in the event of failure, the chances of surrounding collateral damage to personnel or equipment is greatly reduced.

Table 2: Typical life cycle cost breakdown example for a vertical lineshaft pump

C_{ic}	Initial capital – two pumps @ US\$ 75 000 each	US\$ 150 000
C_{in}	Installation 0.75 x C_{ic}	US\$ 112 500
C_e	Electrical 51 kW x US\$ 0.08/kWh x 8760 hrs *15 years	US\$ 536 000
C_e	Water flush 3 GPM x US\$ 0.02/gal * 60 min/hr * 8760 hrs/year x 15 years	US\$ 473 000
C_o	Operating cost (US\$ 2000 operator allocation x 15 years)	US\$ 30 000
C_m	Maintenance – two pumps @ US\$ 75 000/year x 15 years	US\$ 2 250 000
C_s	10 000 bpd/@ US\$ 3/bbl margin + 750 tbd coke @ US\$ 50/t = US\$ 67 000/day margin. Estimated 0.5 days/year lost production due to pump related slowdown or outages x 15 years	US\$ 500 000
C_{env}	Environmental cost – estimated @ 5% of pump cost/year = US\$ 3750 x 15 years	US\$ 112 000
C_d	2 x US\$ 150 000 capital cost	US\$ 300 000
total	Total life cycle costs	US\$ 4 463 500

Seal-less zero emission LNG pump solutions

10. High speed designs and variable speed control⁸

Companies such as Nikkiso Cryo Inc. have a history of variable speed operation and high speed pumping designs, which have been operating successfully for many years in the field. Experience with the Sundyne/Sundstrand high speed pump designs, together with experience in aerospace rocket engine booster pump technology with speeds up to 92 000 rpm, creates an environment where the strengths and weaknesses of high speed design are understood and appreciated. Benefits of high speed pump design include:

- Smaller footprint with compact size and light weight, resulting in lower installation costs.
- High efficiency with proven high reliability under field operation conditions, resulting in a lower Opex.
- Reduced maintenance cost due to compact size and horizontal assembly features.
- Lower material cost of construction due to the smaller size, resulting in lower Capex price.
- Reduced total life cycle costs due to reduced Capex and Opex cost advantages.
- Superior process control and lower operating energy costs due to variable frequency drive (VFD) operation.

11. Evaluating life cycle cost⁹

It is important to evaluate all of the features and benefits offered by the seal less pumps vs. other types of pumps. Pump life cycle cost pertains to the total cost associated with installation, operation, maintenance and decommissioning activities during the course of a pump's installed life, often 15 – 20 years and sometimes more. Most people who deal with pumps and pumping systems recognize that the initial capital outlay for a pumping system is small in comparison to the life cycle cost associated with the installed equipment.

The problem is that many do not have life cycle costs quantified in such a way that they can be used effectively to make cost saving decisions. Below is a suggested formula, and Table 2 shows an example of a life cycle cost evaluation that demonstrates the importance of evaluating the true costs of less expensive initial capital pumps:

Seal-less zero emission LNG pump solutions

Total life cycle cost = initial capital cost + installation and commissioning costs + energy costs (electricity, steam, water, nitrogen) + operator costs (normal system supervision) + maintenance costs + downtime and lost production costs + environmental costs (related to leakage, emissions or decontamination) + final decontamination and disposal costs.

12. Selecting an LNG pump

Individuals with reliable engineering backgrounds and an acute awareness of how and why pumps fail are best equipped to conduct the initial pump selection and specification process. The possible impact of a number of issues, including the ones mentioned in this article, should be considered, and are summarized below:

- One must keep in mind the potential value of selecting pumps that cost more initially, but last much longer between repairs. The mean time between failures (MTBF) of a better SMP may be many years longer than that of its external motor pump counterpart.
- Consider that the published average cost of pump failures does not include lost opportunity costs for production, delivery and plant operations, where these costs can quickly dwarf the initial cost of the equipment.
- Where spending time and effort for pre-purchase reviews of pump proposals, it makes economic sense to concentrate on the typical problems encountered with centrifugal pumps. One should attempt to eliminate these problems before the pump ever reaches the field.
- Owners/operators should insist that total life cycle cost evaluations are included with any equipment recommendation or evaluation. Table 2 shows the initial capital cost of US\$ 150 000 vs. total life cycle costs of US\$ 4 463 500 – a 30 times cost ratio.
- There are several critically important pump applications where buying on price alone is almost certain to cause costly failures. These include the following:
 - Applications with insufficient net positive suction head (NPSH) or low NPSH margin ratios.
 - High specific-speed pumps.
 - Feed, transfer and product pumps without which the plant will not run.
 - Vertical turbine deep-well pumps.
 - Seal vs. seal less pumps.

Seal-less zero emission LNG pump solutions

13. Conclusion

The submerged electric motor pump has been around now for over 50 years and has proven itself as an excellent solution for pumping LNG, NGLs, ethylene and other liquid hydrocarbons. Small scale LNG owners and operators can achieve significant operating reliability improvements and reduced total life time costs by specifying SMPs for their facilities.

14. References

1. Ffooks, R., 'Natural Gas By Sea – the Development of a New Technology', Witherby & Co. Ltd, London, 1979.
2. Van den Handel, R., J.A.N., and Kimmel, H.E., 'A New Generation of Liquid Expanders in Operation at Oman LNG', Proceedings of the Gastech 2000, Houston, Texas, USA, November 2000.
3. Netzel, J., 'What Do Seal Failures Really Cost?', Article based on a presentation delivered at MARTS2008, April 2008.
4. Flood, S., 'Mechanical Seal Reliability – What Realistically can be Achieved', IMechE Mechanical Sealing Technology Seminar, London, UK, April 2007.
5. Loughman, D., 'Unique Requirements Regarding The Installation, Operation and Maintenance Of Cryogenic Submerged Motor Pumps', BPMA Pump Users Forum – Managing Lifetime Costs, May 1994.
6. Nikkiso Cryo Inc's SMPs and thrust balance pistons can work under extreme conditions, as demonstrated in a video currently available here: <http://www.lngindustry.com/videos/>. NCI carried out qualification testing for Exceletrate's FSRU, which ensured NCI SMPs were able to maintain full send out capacity during Hurricane Katrina while stationed in the Gulf.
7. Loughman, D., and Cullen, D., 'Submerged Electric Motor Pumps for Marine Liquefied Gas Carriers', World Pumps Magazine, September 1996.
8. Wahl, F. A., 'LNG Pumps For Floating Units', Proceedings LNG17, Poster Session, Houston, Texas, USA, 2013.
9. Russell, D. P., 'Evaluating Life Cycle Cost – Life Cycle Cost Calculator', Lawrence Pumps Inc., available at www.lawrencepumps.com

Seal-less zero emission LNG pump solutions

15. Bibliography

- ‘Technically Recoverable Shale Oil and Shale Gas Resources: An Assessment of 137 Shale Formations in 41 Countries Outside the United States’, US Energy Administration Information, June 2013.
- Bloch, Heinz, P., and Budris, A., ‘Pump User’s Handbook: Life Extension’, Fairmont: Lilburn, 2006.